

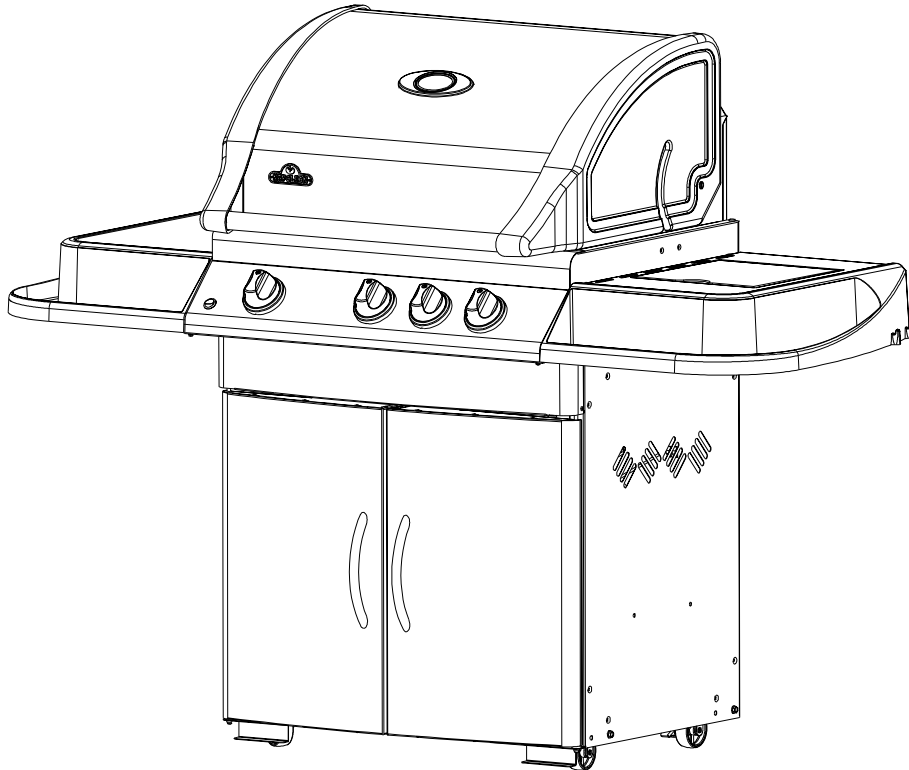

**GOURMET GRILLS**

*Award Winning Products*



**ASSEMBLY AND OPERATING INSTRUCTIONS**

## **MIRAGE 485**

**OUTDOOR STAINLESS STEEL GAS GRILL**

**NOTICE TO INSTALLER:  
LEAVE THESE INSTRUCTIONS  
WITH THE GRILL OWNER FOR  
FUTURE REFERENCE**

**⚠ DANGER**

**IF YOU SMELL GAS:**

- Shut off gas to the appliance.
- Extinguish any open flame.
- Open lid.
- If odor continues, keep away from the appliance and immediately call your gas supplier or your fire department

**DO NOT TRY TO LIGHT THIS APPLIANCE WITHOUT READING LIGHTING INSTRUCTIONS  
SECTION OF THIS MANUAL**



NAPOLEON APPLIANCE CORPORATION,  
214 BAYVIEW DR., BARRIE, ONTARIO, CANADA L4N 4Y8 PHONE: (705)726-4278  
FAX: (705)725-2564 EMAIL: [care@nac.on.ca](mailto:care@nac.on.ca) WEB SITE: [www.napoleongrills.com](http://www.napoleongrills.com)

N415-0156 APR 11/07

# THANK YOU FOR CHOOSING NAPOLEON

NAPOLEON products are designed with superior components and materials, and are assembled by trained craftsmen who take great pride in their work. The burner and valve assembly are leak tested and test-fired at a quality test station. This grill has been thoroughly inspected by a qualified technician before packaging and shipping to ensure that you, the customer, receive the quality product you expect from NAPOLEON.

We at Napoleon are dedicated to you, "our valued customer". It is our goal to provide you with the necessary tools to make this an unforgettable grilling experience. This manual is provided to assist you in assuring your new grill is assembled, installed, maintained and cared for properly. It is important to read and understand this entire manual before operating your new grill to ensure you fully understand all safety precautions and features your grill has to offer. By carefully following the instructions inside this manual you will enjoy years of trouble free grilling. For whatever reason if we fail to meet your expectations please call our customer service department at 1-866-820-8686 between 9 AM and 5 PM (eastern standard time) or visit our website.



## NAPOLEON GAS GRILL PRESIDENT'S LIMITED LIFETIME WARRANTY

NAPOLEON warrants the following materials and workmanship in your new NAPOLEON gas grill against defects for as long as you own the gas grill. This covers: aluminum castings (excluding paint), LUXIDIO trays, wheels, knobs, stainless steel burners, stainless steel lid inserts, and lid handles. Subject to the following conditions. During the first five years NAPOLEON will provide replacement parts at our option free of charge. From the sixth year to lifetime NAPOLEON will provide replacement parts at 50% of the current retail price.

Components such as stainless steel sear plates, stainless steel cooking grids, igniters (excluding batteries), temperature gauges and brass valves are covered and NAPOLEON will provide parts free of charge during the first two years of the limited warranty.

Components such as regulators, casters, warming racks, hoses and connectors, fasteners and accessories are covered and NAPOLEON will provide parts free of charge during the first year of the limited warranty.

NAPOLEON shall not be liable for any transportation charges, labour costs or export duties.

## CONDITIONS AND LIMITATIONS

"NAPOLEON warrants its products against manufacturing defects to the original purchaser only (ie., the individual or legal entity (registered customer) whose name appears on the warranty registration card filed with NAPOLEON), provided that the purchase was made through an authorized NAPOLEON dealer and is subject to the following conditions and limitations:"

This factory warranty is non-transferable and may not be extended what-so-ever by any of our representatives.

The gas grill must be installed by a licenced, authorized service technician or contractor. Installation must be done in accordance with the installation instructions included with the product and all local and national building and fire codes.

This limited warranty does not cover damages caused by misuse, lack of maintenance, grease fires, hostile environments, accident, alterations, abuse or neglect and parts installed from other manufacturers will nullify this warranty.

This limited warranty further does not cover any scratches, dents, painted finishes, corrosion or discolouring by heat, abrasive and chemical cleaners, nor chipping on porcelain enamel parts, nor any components used in the installation of the gas grill.

Should deterioration of parts occur to the degree of non-performance within the duration of the warranted coverage, a replacement part will be provided.

In the first year only, this warranty extends to the replacement of warranted parts which are defective in material or workmanship provided that the product has been operated in accordance with the operation instructions and under normal conditions.

After the first year, with respect to this President's Limited Lifetime Warranty NAPOLEON may, at its discretion, fully discharge all obligations with respect to this warranty by refunding to the original warranted purchaser the wholesale price of any warranted but defective part(s).

**NAPOLEON will not be responsible for the installation, labour or any other costs or expenses related to the re-installation of a warranted part, and such expenses are not covered by this warranty.**

Notwithstanding any provision contained in this President's Limited Lifetime Warranty NAPOLEON's responsibility under this warranty is defined as above and it shall not in any event extend to any incidental, consequential, or indirect damages.

This warranty defines the obligation and liability of NAPOLEON with respect to the NAPOLEON gas grill and any other warranties expressed or implied with respect to this product, its components or accessories are excluded.

NAPOLEON neither assumes, nor authorizes any third party to assume, on its behalf, any other liabilities with respect to the sale of this product. NAPOLEON will not be responsible for: over firing, blow outs caused by environmental conditions such as strong winds, or inadequate ventilation.

Any damages to the gas grill due to weather damage, hail, rough handling, damaging chemicals or cleaners will not be the responsibility of NAPOLEON.

The bill of sale or copy will be required together with a serial number and a model number when making any warranty claims from NAPOLEON. The warranty registration card must be returned within fourteen days to register the warranty or you can register on-line at [www.napoleongrills.com](http://www.napoleongrills.com).

NAPOLEON reserves the right to have its representative inspect any product or part prior to honouring any warranty claim.

NAPOLEON shall not be liable for any transportation charges, labour costs, or export duties.

## SAFETY PRECAUTIONS



### WARNING

Do not store or use gasoline or other flammable liquids or vapor in the vicinity of this or any other appliance. An L.P. cylinder not connected for use must not be stored in the vicinity of this or any other appliance. Keep area clear and free from combustible



### WARNING

Failure to follow these instructions could result in property damage, personal injury or death. Read and follow all warnings and instructions in this manual prior to operating grill.

## SAFE OPERATING PRACTICES



### WARNING



**DANGER: READ ALL INSTRUCTIONS CAREFULLY BEFORE OPERATING GRILL. FAILURE TO FOLLOW THESE INSTRUCTIONS EXACTLY COULD RESULT IN A FIRE CAUSING SERIOUS INJURY OR DEATH.**

- Read the entire instruction manual before operating grill.
- Under no circumstance should this gas grill be modified.
- Follow lighting instructions carefully when operating grill.
- Gas must be turned off at the propane cylinder or at the natural gas supply valve when the gas grill is not in use.
- Keep children and pets away from hot grill, DO NOT allow children to climb inside cabinet.
- Do not leave the grill unattended while in use.
- Do not move grill when hot or operating.
- This gas grill is not intended to be installed in or on recreational vehicles and/or boats.
- This gas grill must only be stored outdoors in a well-ventilated area and must not be used inside a building, garage or any enclosed area.
- Maintain proper clearance to combustibles (16" to rear of unit 7" to sides). Additional clearance is recommended near vinyl siding or large panes of glass.
- At all times keep the ventilation openings of the cylinder enclosure free and clear from debris.
- Do not locate unit under unprotected combustible construction.
- Do not locate in windy settings. High winds adversely affect the cooking performance of the gas grill.
- When the gas grill is stored indoors, the propane cylinder must be disconnected from the grill and stored outdoors in a well ventilated area, disconnected cylinders must not be stored in a building, garage or other enclosed area.
- Inspect the fuel line hose before each use. If there is evidence of excessive abrasion or wear, it must be replaced before using the gas grill, with a replacement hose assembly specified by the manufacturer.
- Never store a spare LP gas cylinder under or near this grill.
- Never fill the cylinder beyond 80 % full.
- Do not attempt to use a cylinder which is not equipped with a QCC1 type connection.
- Leak test all connection before first use, even if the grill was purchased fully assembled, annually or whenever any gas component has been replaced.
- Never use natural gas in a unit designed for liquid propane gas.
- Never use charcoal briquets or lighter fluid in a gas grill.
- Burner controls must be off when turning supply cylinder on.
- Do not light burner with lid closed.
- Do not operate rear burner with main burner operating.
- The top lid is to be closed during the preheat period.
- Do not route hose underneath drip pan-proper hose clearance to bottom of unit must be maintained.
- Clean grease tray and sear plates regularly to avoid build-up which may lead to grease fires.
- Ensure sear plates are positioned properly according to sear plate installation instructions.
- Do not use side shelves to store lighter, matches or any other combustibles.
- Keep fuel line away from heated surfaces
- Keep electrical supply cords away from water or heated surfaces.
- Inspect infrared burner venturi tube for spider webs and other obstructions periodically. Clean the tubes completely if you find any such obstructions.
- The outdoor cooking gas appliance and its individual shutoff valve must be disconnected from the gas supply piping system during any pressure testing of that system at test pressures in excess of 0.5psi (3.5kPa).
- The outdoor cooking gas appliance must be isolated from the gas supply piping system by closing its individual manual shutoff valve during any pressure testing of the gas supply piping system at test pressures equal to or less than 1/2 psi (3.5 kPa).

# CYLINDER SPECIFICATIONS/GAS HOOK UP



This gas barbecue is certified under Canadian and American national standards, CAN/CSA-1.6-2005 and ANSI Z21.58 -2005 respectively for outdoor gas grills and should be installed to conform with local codes. In absence of local codes, install to the current CAN/CGA-B149.1 Propane Installation Code in Canada or to the National Fuel Gas Code, NFPA54/ANSI Z223.1 in the United States.

If a rotisserie motor is used, it must be electrically grounded in accordance with local codes or, in absence of local codes, with the current CSA C22.1 Canadian electrical code in Canada or the National Electrical Code, ANSI/NFPA 70 in the United States.

**CALIFORNIA PROPOSITION 65:** The burning of gas fuel creates by products, some of which are on the list as substances known by the State of California to cause cancer or reproductive harm. When cooking with gas, always ensure adequate ventilation to the unit, to minimize exposure to such substances.

**PROPANE CYLINDER SPECIFICATIONS:** A dented or rusty cylinder may be hazardous and should be checked by your propane supplier. Never use a cylinder with a damaged valve. Use only a propane supply cylinder constructed and marked in accordance with the specifications for LP-gas cylinders of the Canadian Transport Commission (CTC) or the US Department of Transportation (DOT). This appliance has been designed for use with a 20lb. (9.1 kg) size propane cylinder only (not supplied).

The propane cylinder must be provided with a shut-off valve terminating in a propane cylinder valve type QCC1, and a safety relief device having direct communication with the vapour space of the cylinder. The cylinder supply system must be arranged for vapour withdrawal and the cylinder shall include a collar to protect the cylinder valve. The cylinder shall incorporate an OPD (overfill protection device).

**CYLINDER CONNECTION:** Ensure that the gas regulator hose is kink free. Remove the cap or plug from the cylinder fuel valve. Insert the black QCC1 regulator nipple onto the QCC1 fuel valve. Hand tighten clockwise. Do not use tools. Leak test all joints prior to using the barbecue. A leak test must be performed annually, and each time a cylinder is hooked up, or if a part of the gas system is replaced.

## **PROPANE CYLINDER INSTALLATION:**

Check that the cylinder valve is closed by turning the knob clockwise.

Check that the grills burner knobs are in the off position.

Open Cabinet doors.

Place the cylinder into the tank holder in bottom of shelf.

Position the cylinder so that the valve faces toward the front of the unit.

Attach regulator hose.

**IMPORTANT:** Use only the pressure regulator and hose assembly provided with this barbecue. Replacement pressure regulators and hose assemblies must be specified by the manufacturer. Do not store propane cylinder or spare cylinder on the shelf beneath the barbecue. The regulator must be attached so that no part of the hose touches the underside of the grill or drippan. A fire will result if these directions are ignored.

The regulator supplies a pressure of 11 inches water column to the gas grill and has a QCC1 type fitting. Cylinders to be used with this unit must be supplied with a Sherwood #3349 QCC1 cylinder valve. A QCC1 cylinder has a positive seating connection, which will not allow gas flow until a positive seal has been achieved. It is also equipped with an excess flow device. In order to attain full flow to the barbecue, **the valves must be in the off position when the cylinder valve is turned on.**

**NATURAL GAS HOOK-UP:** This natural gas grill is supplied with a 10ft supply hose (complete with a quick disconnect) designed for natural gas and certified for outdoor use. The gas grill is designed to operate at an inlet pressure of 7 inches water column. Piping and valves upstream of the quick disconnect are not supplied.

The quick disconnect must not be installed in an upward direction and a readily accessible manual shut-off valve must be installed upstream of, and as close to, the quick disconnect as is feasible. The flared end of the hose must be connected to the fitting on the end of the flex tube as illustrated in the *Natural Gas Hose Attachment* diagram. Tighten using two wrenches. (*Do not use thread sealer/pipe dope.*) **These connections must be made by a licensed gas installer.** Leak test all joints prior to using the gas grill.

# LIGHTING INSTRUCTIONS

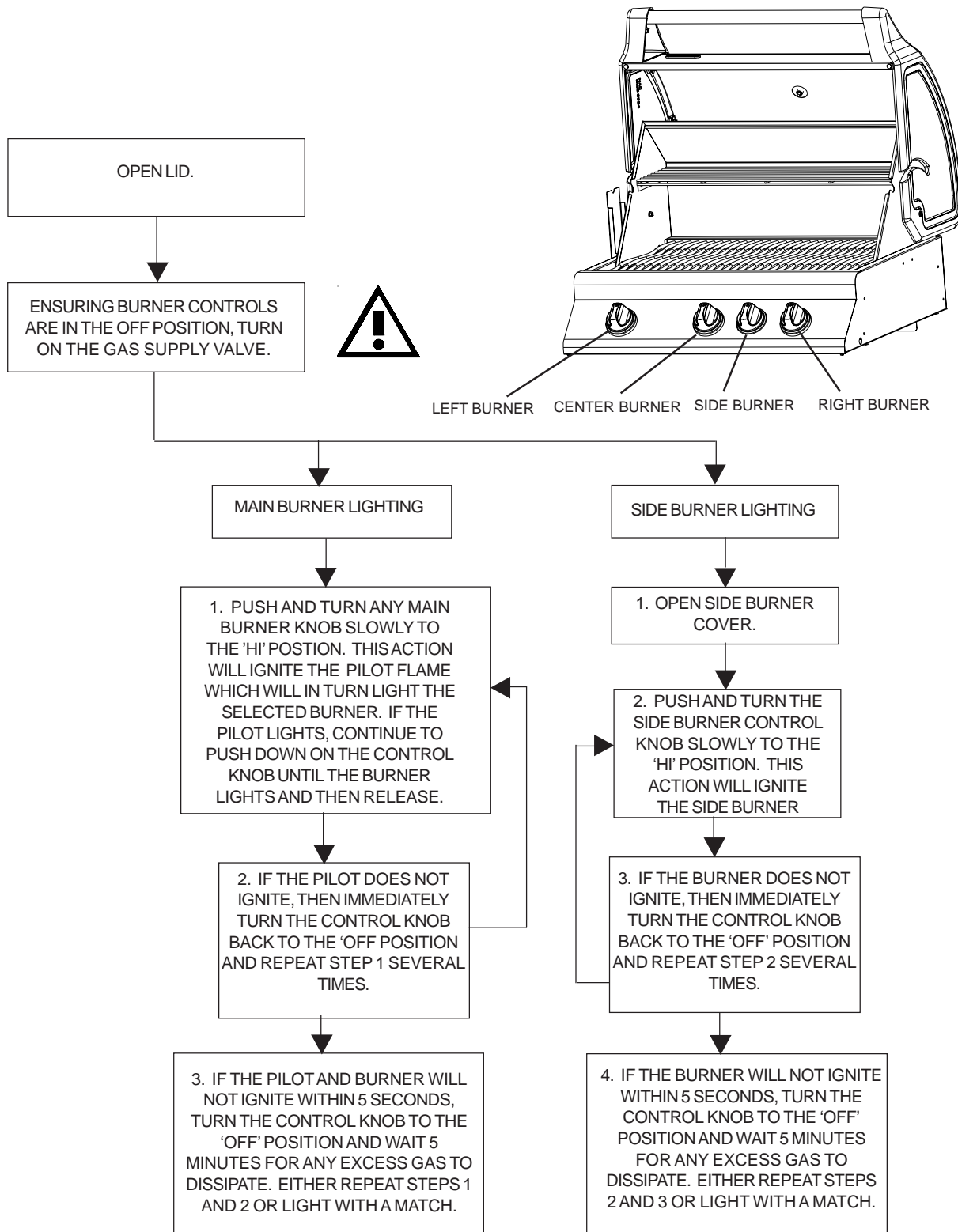

The propane cylinder is equipped with an excess flow device. Unless all burners are turned off prior to turning the cylinder on, only small flames will be achievable.



If lighting the unit with a match, clip the match into the supplied lighting rod. Hold the lit match down through the grill and sear plate while turning the corresponding burner valve to high.

# OPERATING THE GRILL

## BURN IN PROCEDURE

When lit for the first time, the gas grill will emit a slight odour. This is a normal temporary condition caused by the "burn-in" of internal paints and lubricants used in the manufacturing process and will not occur again. Simply run the main burners on high for approximately ½ hour with the lid closed.

## MAIN BURNER USE:

When searing foods, preheating is recommended by operating all main burners in the high position with the lid closed for approximately 15 minutes. Food cooked for a short period of time (fish, vegetables) may be grilled with the lid open. Cooking with the lid closed will ensure higher, more even temperatures that will reduce cooking time and cook meat more evenly. When cooking very lean meats, such as chicken breasts, or lean pork, the grids can be oiled before pre-heating to reduce sticking. Cooking meat with a high degree of fat content, may create flare-ups. Either trim some fat or reduce temperatures to prevent this. Should a flare-up occur, move food away from flames, reduce heat. Leave the lid open. See 'Your All Season Grill' cookbook by Napoleon for more detailed instructions.

### DIRECT COOKING:

Place food to be cooked on the grill directly over the heat. This method is generally used for searing or for foods that do not require prolonged cooking times - hamburgers, steaks, chicken pieces, vegetables, etc. The food is first seared to trap in the juices and flavor, and then the temperature is lowered to finish cooking the food to your preference.

### INDIRECT COOKING:

With one or more burners operating place food to be cooked on the grill over one of the burners that is not operating. The heat circulates around the food, cooking slowly and evenly. Cooking in this manner is much the same as cooking in your oven and is generally used for larger cuts of meats such as roasts, chickens or turkeys, but can also be used for cooking foods that are prone to flare ups. Cooking in this method with lower temperatures and slower cooking times will result in tender foods every time you grill.

### INFRARED MAIN BURNER USE: (optional)

1. Operate on high for 5 minutes with the lid closed or until the ceramic burners glow red.
2. Place food on grills, searing in juices approximately 2 minutes per side.
3. Depending upon your taste, continue cooking over infrared burner on high, medium or low, turning food frequently, or place food away from infrared burners, close lid, and allow oven temperature to slowly finish cooking your food.

**PROTECTION OF YOUR INFRA RED BURNERS** - The infrared burners of your grill are designed to provide a long service life. However, there are steps you must take to prevent cracking of their ceramic surfaces, which will cause the burners to malfunction.

1. Never let water come in direct contact with your ceramic burner.
2. Avoid impact with hard objects.
3. In order for the burners to function properly, hot air must have a way to escape the grill. If the hot air is not allowed to escape, the burners may become deprived of oxygen, causing them to crack. Do not cover more than 75% of the cooking surface with solid metal (ie. griddle or large pan).

Damage caused by failure to follow these steps is not covered by your grill warranty.

### IMPORTANT

- **Do not allow cold water (rain, sprinkler, hose, etc.) to come in contact with hot ceramic burners. A large temperature differential can cause cracking of the ceramic tile.**

### SIDE BURNER USE:

The side burner can be used like any range top burner, for gravies, soups etc. The gas grill should be located so that the side burner is protected from the wind, because the wind will adversely affect it's performance. **DO NOT** use side burner to deep fry foods as cooking with oil can create a dangerous situation.

# MAINTENANCE/CLEANING INSTRUCTIONS

It is recommended that this gas grill be thoroughly inspected and serviced annually by a qualified service person.

- Do not use pressure washer to clean any part of the unit.

Ensure that the burners are turned off prior to cleaning. Avoid unprotected contact with hot surfaces. Clean grill in an area where cleaning solutions will not harm decks, lawns or patios. Do not use oven cleaner to clean any part of this gas grill. Do not use a self cleaning oven to clean cooking grids or any other parts of the gas grill. Barbecue sauce and salt can be corrosive and will cause rapid deterioration of the gas grill components unless cleaned regularly.

Turn off the gas at the source and disconnect unit before servicing. Maintenance should only be done when the grill is cool, to avoid the possibility of burns. A leak test must be performed annually, and whenever any component of the gas train is replaced.

**COMBUSTION AIR ADJUSTMENT - (This must be done by a qualified gas installer.)** The air shutter is factory set and should not have to be adjusted under normal conditions. However, some extreme field conditions may exist that require adjustment. When the air shutter is adjusted correctly, the flames will be dark blue with light blue tips, and occasional yellow tips.

If the burner is getting too little air, the flames will be lazy yellow, and possibly produce soot. If the burner is getting too much air, the flames will be lifting erratically from the burner and may cause difficulties when lighting.

1. To adjust the air shutter, remove cooking grids and sear plates and leave lid open. The back cover must be removed for back burner air shutter adjustment.

2. Loosen air-shutter lock screw and open or close air shutter as required. The normal settings are:

Main Burner	Propane	5/32"
	Natural	5/32"

3. Light burners and set to high. Visually inspect burner flames. When shutters are set, turn burners off, tighten locking screw, and replace removed parts. Ensure that the insect screens are installed.

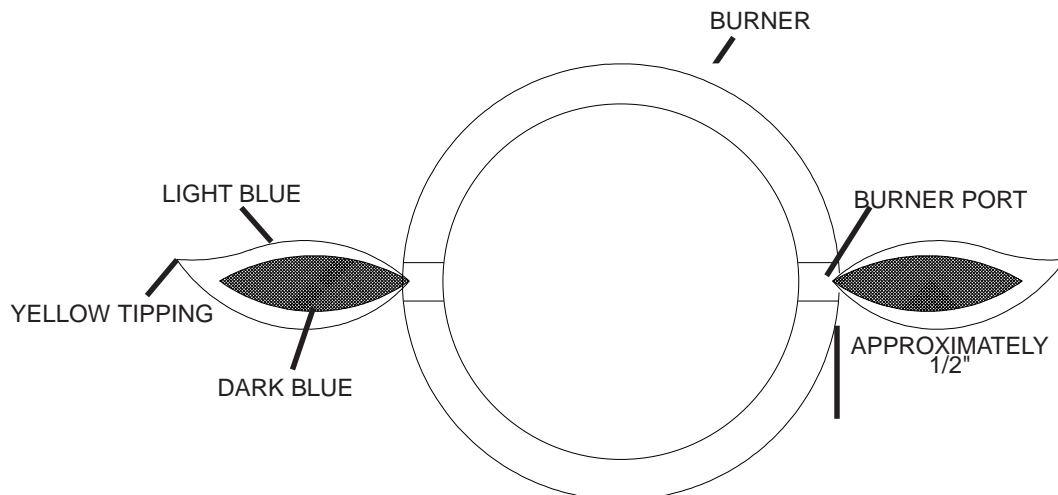

**GRIDS AND WARMING RACK** - The grids and warming rack are best cleaned during the pre-heat period with a soft brass wire brush. Steel wool can be used for stubborn stains. Stainless grids will discolour permanently from normal usage, due to the high temperature of the cooking surface.

**CLEANING INSIDE THE GAS GRILL** - Remove cooking grids. Use a soft brass wire brush to clean loose debris from casting sides and insides of the lid. Scrape sear plates with a putty knife or scraper, and use a wire brush to remove ash. Remove sear plates and brush debris off of burners with a brass wire brush. Brush all debris from inside the gas grill into the removable drip pan. Ensure that the sear plates are placed properly when they are reinstalled (Check assembly instructions for proper orientation).

**DRIP PAN** - Slide the drip pan out for easy cleaning. It should be cleaned frequently (every 4-5 uses) to avoid grease buildup. Grease and excess drippings pass through to the drip pan, located under the gas grill, and accumulate in the disposable grease tray below the drip pan. Accumulated grease can cause a fire hazard. Do not line the drip pan with aluminum foil or sand, as it can prevent the grease from flowing properly. The pan should be scraped out with a putty knife or scraper, and all the debris should be scraped into the disposable grease tray. This tray should be replaced every two to four weeks, depending on gas grill usage. For supplies, see your Napoleon Gas Grill dealer.

# MAINTENANCE/CLEANING INSTRUCTIONS

**HOSE** - Check for abrasion, melting, cuts and cracks. If any of these conditions exist, do not use gas grill. Have part replaced by your Napoleon Gas Grill dealer, or qualified gas installer.

**CLEANING THE OUTSIDE OF THE GAS GRILL** - Do not use abrasive cleaners to clean any painted, porcelain or stainless steel parts. Porcelain enamel components must be handled with additional care. The baked on enamel finish is glass like, and will chip if struck. Touch-up enamel is available from your Napoleon Gas Grill dealer. Exterior grill surfaces should be cleaned while warm to the touch, with warm soapy water. To clean stainless surfaces, use a stainless steel cleaner or a non-abrasive cleaner. Always wipe in the direction of the grain. Do not use steel wool, as it will scratch the finish. Stainless steel parts will discolour when heated, usually to a golden or brown colour. This discolouration is normal and will not affect the performance of the grill.

**TUBE BURNER** - The burner is made from heavy wall 304 stainless steel, but due to the extreme heat and corrosive environment, surface corrosion will occur. Use a brass wire brush to remove surface corrosion. Clean any blocked ports using an opened paper clip. Do not enlarge the burner ports. Spiders and insects are attracted to the smell of propane and natural gas. The burner is equipped with an insect screen on the air shutter, which will reduce the likelihood of insects building nests inside the burner, but does not entirely eliminate the problem. The nest or web will cause the burner to burn with a soft yellow or orange flame or cause a fire (flashback) at the air shutter underneath the control panel. To clean the inside of the burner, it must be removed from the gas grill. Remove the screw located in the center of each burner. Lift the back of the burner upwards to remove. Use a flexible venturi tube cleaning brush to clean out the inside of the burner. Shake any loose debris out of the burner, through the gas inlet. Ensure that the insect screen is clean, tight, and free of any lint or other debris. Check also that the valve orifices are clean. Do not enlarge the orifices. Re-install the burner.



**CAUTION BEWARE OF SPIDERS**

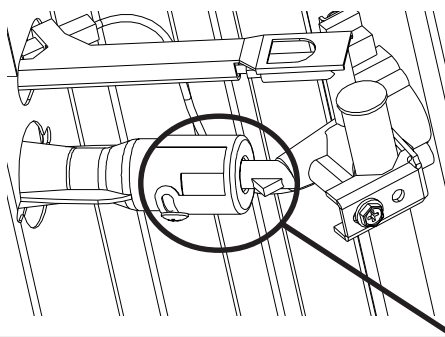
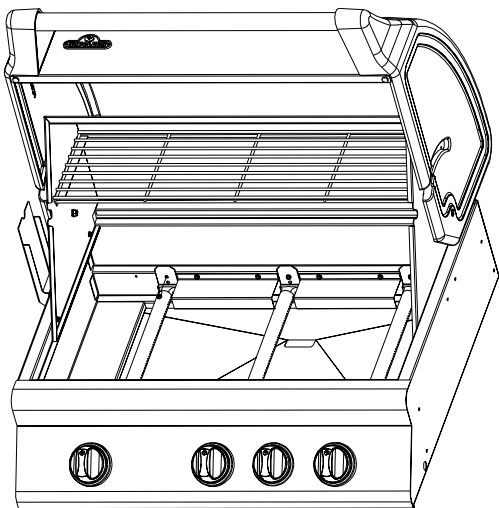
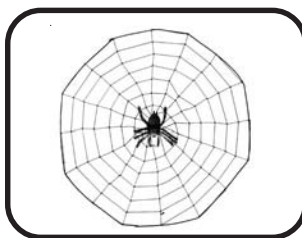

**WARNING**



It is very important when re-installing the burner after cleaning that the valve/orifice enters the burner tube before lighting your gas grill. If the valve is not inside the burner tube a fire or explosion could occur.

**INFRA RED BURNER** - Because of the high intensity of the infrared burner, most drippings and food particles that fall onto the burner surface are immediately incinerated. However, some debris and residue may remain. To remove this residue after cooking, turn the grill on high with lid closed for 5-10 minutes. Never use a brush or pressure washer to clean the infra red burners.



# TROUBLESHOOTING

Problem	Possible Causes	Solution
Low heat / Low flame when valve turned to high.	<p>For propane - improper lighting procedure.</p> <p>For natural gas - undersized supply line.</p> <p>For both gases - improper preheating.</p>	<p>Ensure lighting procedure is followed carefully. All gas grill valves must be in the off position when the tank valve is turned on. Turn tank on slowly to allow pressure to equalize. See lighting instructions.</p> <p>Pipe must be sized according to installation code.</p> <p>Pre-heat grill with both main burners on high for 10 to 15 minutes.</p>
Excessive flare-ups/uneven heat.	<p>Sear plates installed incorrectly.</p> <p>Improper pre-heating.</p> <p>Excessive grease and ash build up on sear plates and in drip pan.</p>	<p>Ensure sear plates are installed with the holes towards the front, and the slots on the bottom. See assembly instructions.</p> <p>Pre-heat grill with both main burners on high for 10 to 15 minutes.</p> <p>Clean sear plates and drip pan regularly. Do not line pan with aluminum foil. Refer to cleaning instructions.</p>
Burners burn with yellow flame, accompanied by the smell of gas.	Possible spider web or other debris, or improper air shutter adjustment.	Thoroughly clean burner by removing. See general maintenance instructions. Open air shutter slightly according to combustion air adjustment instructions.
Flames lift away from burner, accompanied by the smell of gas, and possibly difficulties in lighting.	Improper air shutter adjustment.	Close air shutter slightly according to combustion air adjustment instructions.
Regulator 'Hums' when unit is operating.	Normal occurrence on hot days.	This is not a defect. It is caused by internal vibrations in the regulator, and does not affect the performance or safety of the gas grill. Humming regulators will not be replaced.
Burners will not crosslight each other.	Plugged ports at back of burner.	Clean burner ports. See burner maintenance instructions.
"Paint" appears to be peeling inside lid or hood.	Grease build up on inside surfaces.	This is not a defect. The finish on the lid and hood is stainless steel, and will not peel. The peeling is caused by hardened grease, which dries into paint-like shards, that will flake off. Regular cleaning will prevent this. See cleaning instructions.

# ORDERING REPLACEMENT PARTS

## WARRANTY INFORMATION



MODEL: \_\_\_\_\_  
 DATE OF PURCHASE: \_\_\_\_\_  
 SERIAL NUMBER: \_\_\_\_\_

**(record information here for easy reference)**

Before contacting the customer service department, check the NAC web site for more extensive cleaning, maintenance, troubleshooting and part replacement instructions at [www.napoleongrills.com](http://www.napoleongrills.com). Contact the factory directly for replacement parts and warranty claims. The customer service department is available between 9 AM and 5 PM (Eastern standard time) at 1-866-820-8686 or fax at 1-705-727-4282. In order to process a claim, we must be provided with the following information:

1. Model and serial number of the unit.
2. Part number and description.
3. A concise description of the problem ('broken' is not sufficient).
4. Proof of purchase (photocopy of the invoice).

In some cases the customer service representative may request to have the parts returned to the factory for inspection, before providing replacement parts. The parts must be shipped prepaid to the attention of the customer service department with the following information:

1. Model and serial number of the unit.
2. A concise description of the problem ('broken' is not sufficient).
3. Proof of purchase (photocopy of the invoice).
4. Return Authorization number - provided by the customer service representative.

Before contacting customer service, kindly note that the following items are not covered by the warranty:

- costs for transportation, brokerage or export duties
- labor costs for removal and re-installation
- costs for service calls to diagnose problems
- discoloration of stainless steel parts
- part failure due to lack of cleaning and maintenance, or use of improper cleaners (oven cleaner).

## NAPOLEON APPLIANCE CORPORATION ACCESSORIES / PARTS ORDER FORM FAX TO: 1-705-727-4282

PLEASE PRINT CLEARLY

CUSTOMER NAME: \_\_\_\_\_ DATE: \_\_\_\_\_  
 ADDRESS: \_\_\_\_\_ MODEL #: \_\_\_\_\_  
 \_\_\_\_\_ SERIAL #: \_\_\_\_\_  
 \_\_\_\_\_  
 TELEPHONE: \_\_\_\_\_  
 VISA OR MASTERCARD #: \_\_\_\_\_ EXPIRY DATE: \_\_\_\_\_

QUANTITY	PRODUCT NUMBER	DESCRIPTION

# ASSEMBLY INSTRUCTIONS

**⚠ CAUTION:** During unpacking and assembly it is recommended that you wear work gloves and safety glasses for your protection. Although we make every effort to make the assembly process as problem free and safe as possible, it is characteristic of fabricated steel parts that the edges and corners may be sharp and can cause cuts if handled incorrectly during assembly.

## GETTING STARTED

1. Remove all cart panels, hardware, and grill head from carton. Raise lid and remove any components packed inside. Use the parts list to ensure all necessary parts are included.
2. Do not destroy packaging until grill has been fully assembled and operating to your satisfaction.
3. Assemble BBQ where it is to be used, lay down cardboard or a towel to protect parts from being lost or damaged while assembling.
4. Most stainless steel parts are supplied with a protective plastic coating that must be removed prior to using grill.
5. Follow all instructions in the order that they are layed out in this manual.
6. Two people are required to lift the grill head onto the assembled cart.

## TOOLS REQUIRED FOR ASSEMBLY (tools not included)

3/8(10mm)  
WRENCH  
OR RATCHET

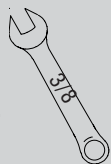

7/16 WRENCH  
OR RATCHET

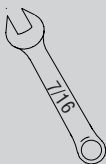

FLAT AND PHILIPS  
SCREWDRIVERS

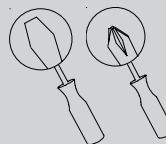

HAMMER



**If you have any questions about assembly or grill operation, or if there are damaged or missing parts please call our customer service department at 1-866-820-8686 between 9 AM and 5 PM (eastern standard time)**

1 x N430-0002  
MAGNET CATCH

## 1 Magnet Installation

Snap magnet into slot in front of bottom shelf.

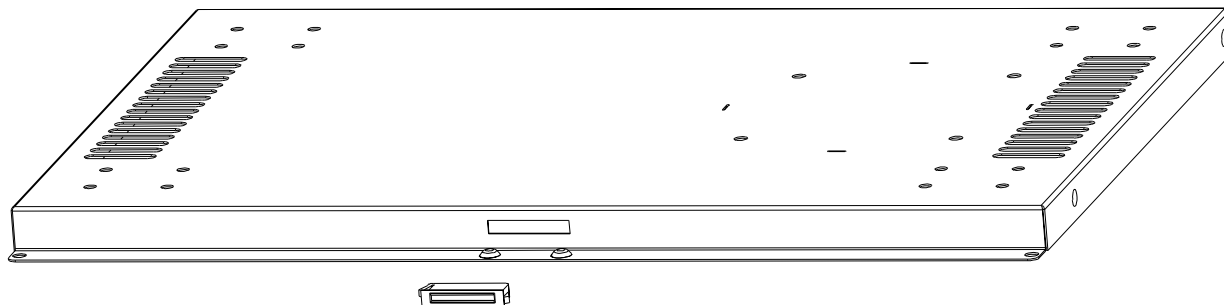

16 X   
N570-0073 (1/4-20 X 3/8")

16 X   
N450-0027 (1/4-20)

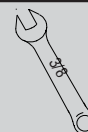

## 2 Caster/Bracket Installation

Attach (4) casters, using (4) 1/4 - 20 X 3/8" screws and (4) 1/4-20 lock nuts for each caster. Attach brackets under front casters as illustrated. Tighten securely.

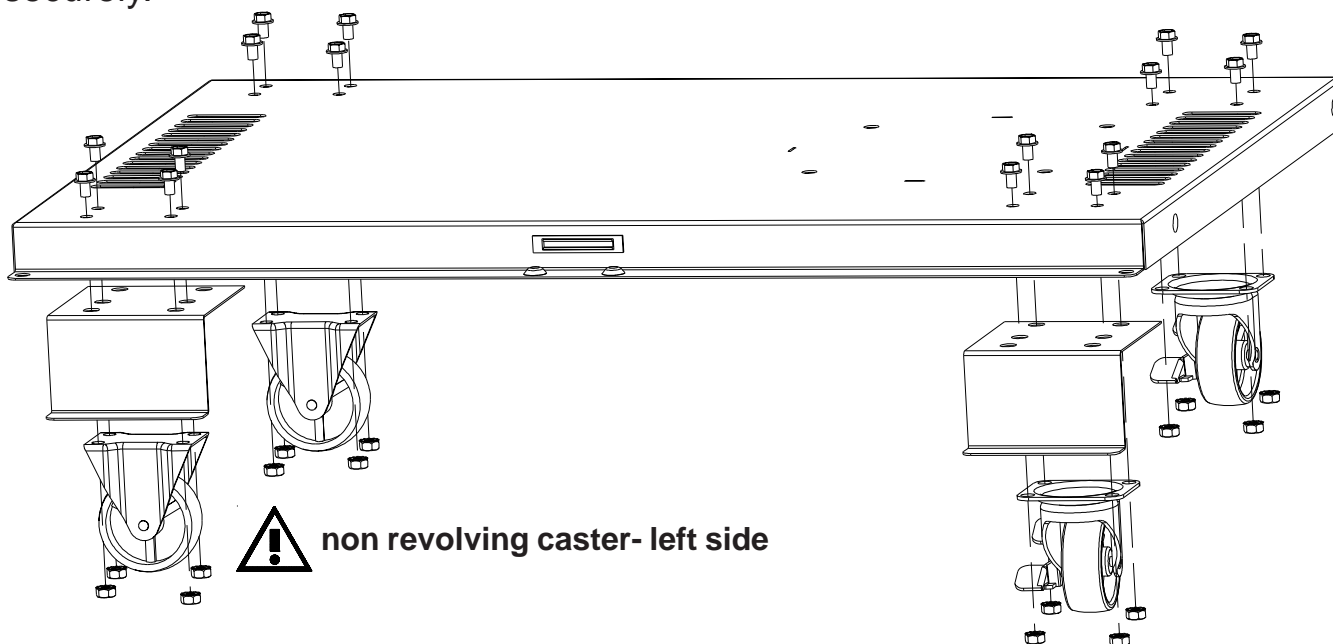



PROPANE ONLY

### 3 Propane Tank Ring Installation

Insert propane tank ring into slots in bottom shelf as shown. Fold tabs over to secure in place.

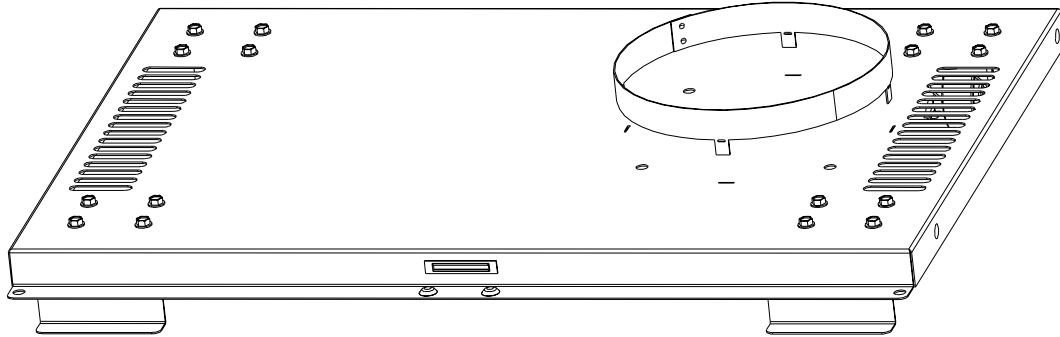

4 X

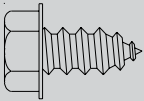

N570-0080 (#14 X 1/2'')

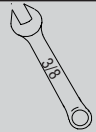

### 4 Left and Right Cart Panel Installation

Install end cart panels ensuring slots in panel are to the top, rest panel on bottom shelf and line up holes. Fasten using (4) #14 x 1/2" screws.

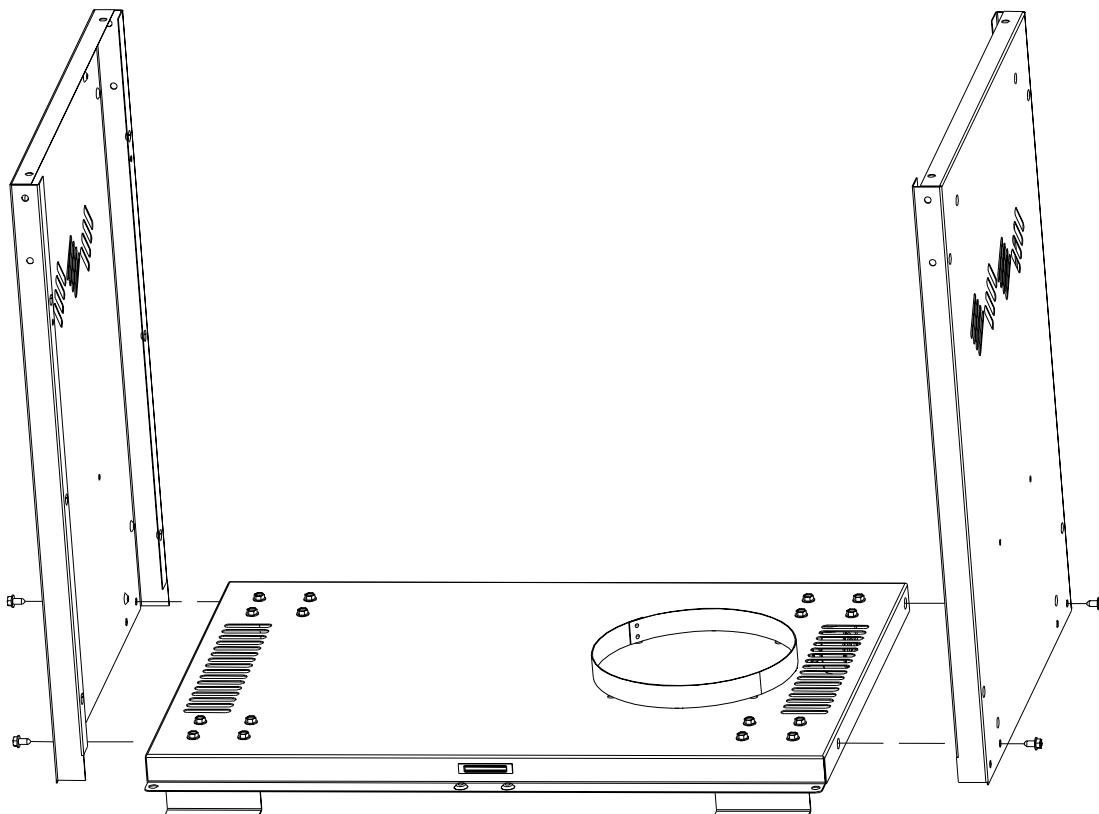

6 X

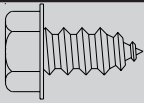

N570-0080 (#14 X 1/2")



## 5 Rear Cart Panel Installation

Fit rear cart panel between the two end panels, ensure large hole in panel is to the bottom right hand corner as illustrated. Fasten using (6) #14 x 1/2" screws, three on each side.

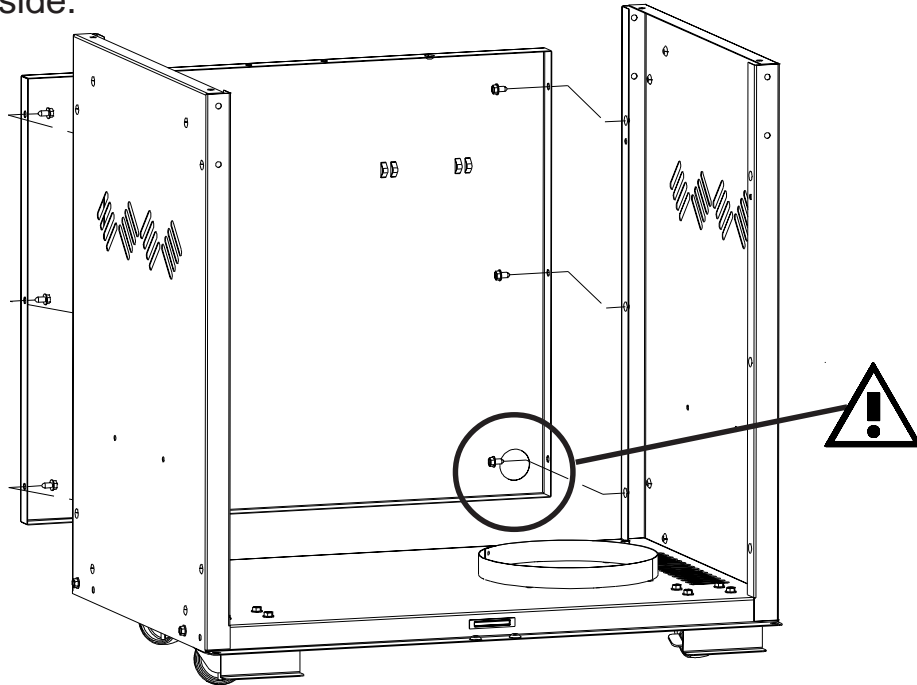

## 6 Condiment Basket / Propane Tank Mount Installation

Rotate basket slightly to allow wire to enter the holes in the side panel. Push through and upwards, rotating to allow the bend in the wire to pass through the holes. Lay basket flat against the side panel. Clip top propane tank mount into slots in back panel. Insert one end at a time, gently bending wire. (When not in use tank mount will lay flat against back panel).

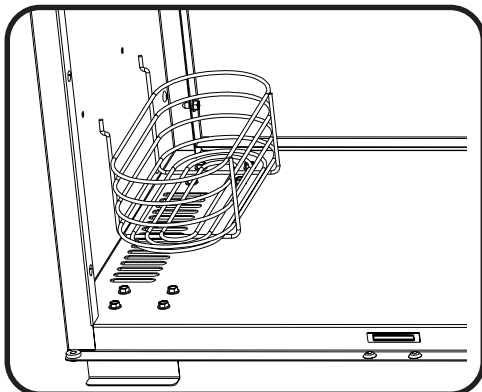

**PROPANE ONLY**

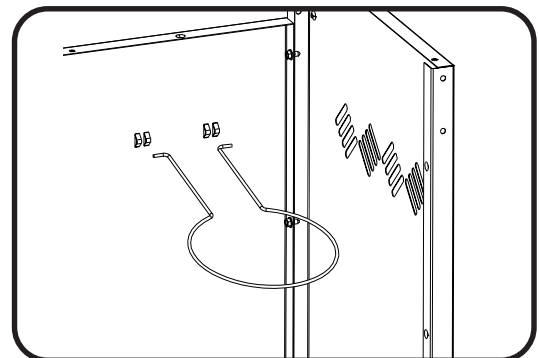

6 X  
N570-0080 (#14 X 1/2")

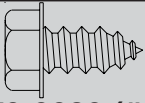

1 x N430-0002  
MAGNET CATCH

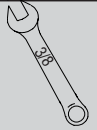

## 7 Front Cabinet Support Installation

Fasten top rail assembly to the front of side panels using (4) #14 x 1/2" screws. For ease of installation start all screws before tightening completely. Attach magnet bracket to bottom of top rail using (2) #14 x 1/2" screws, and snap magnet into place as shown.

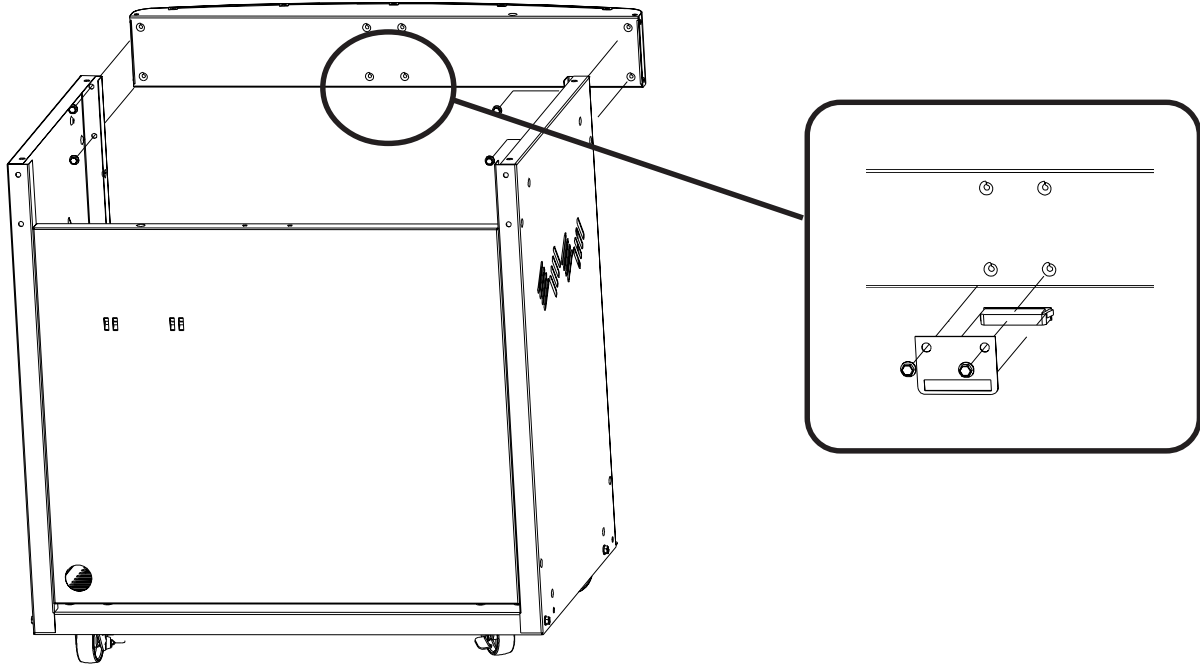

2 X  
N570-0080 (#14 X 1/2")

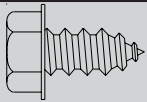

**PROPANE ONLY**

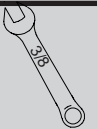

## 8 Propane Tank Heat Shield Installation

Attach propane tank heat shield above propane tank ring. Attach one end under lip of back panel and other end to underside of front cabinet support.

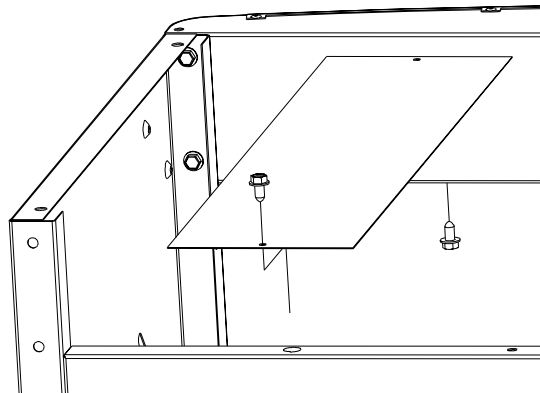

6 x

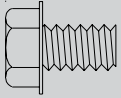

N570-0073 (1/4-20 x 3/8")

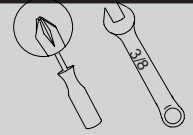

## 9 Grill Head Installation

**⚠️ PROPANE ONLY** - To avoid assembly difficulties, prior to mounting the grill head, remove zip tie holding regulator up under control panel. This was installed at the factory to protect the regulator hose during shipping and is no longer required. (Take care when removing the tie not to damage the hose).

Lift grill head and place on assembled cart, lining up holes in top of side cart panels with holes in bottom of base. Fasten from inside using (4) 1/4-20 x 3/8" screws, two per side. Install battery pack below vent slots on left hand panel using double sided tape supplied with battery pack. Plug wire from LED (lights) located underneath control panel into wire from battery pack. Install rotisserie mount bracket to left side of barbecue as shown using (2) 1/4-20 x 3/8" screws.

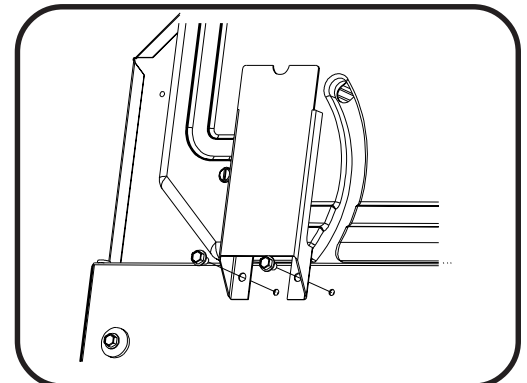
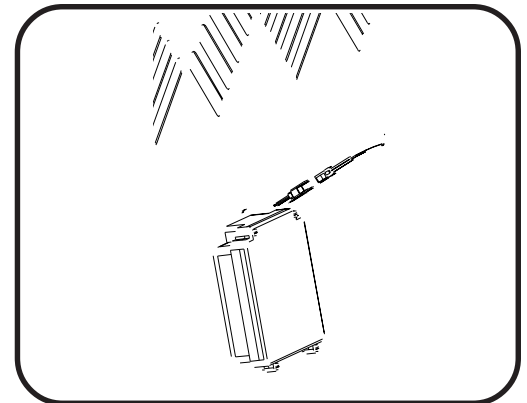
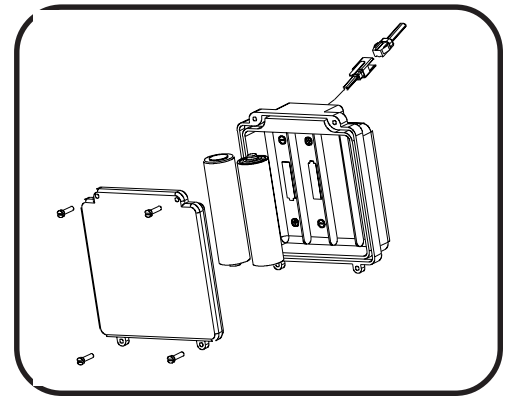
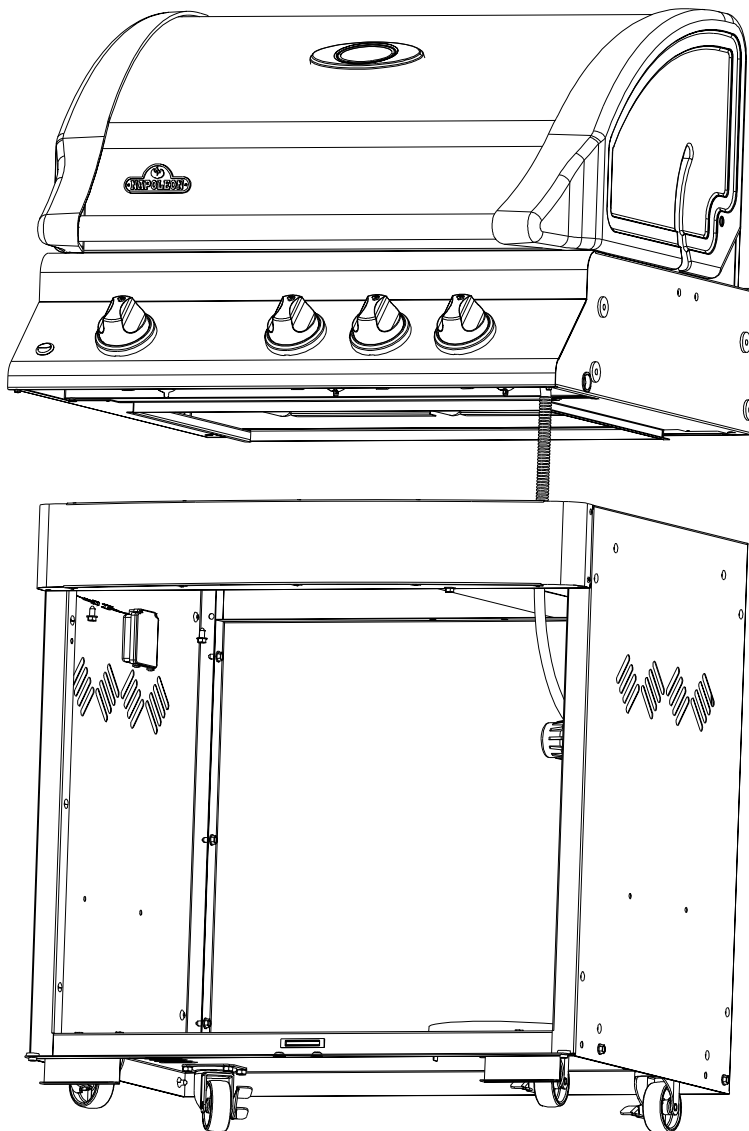

**TWO PEOPLE ARE REQUIRED FOR THIS STEP**



10 x

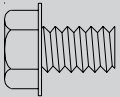

N570-0073 (1/4-20 x 3/8")

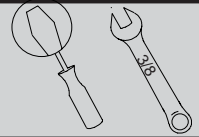

## 10 Assembling End Caps to Side Shelf / Side Burner

Peel protective coating from side shelf / side burner. Attach corresponding end cap as shown using (5) (1/4-20 x 3/8") screws.

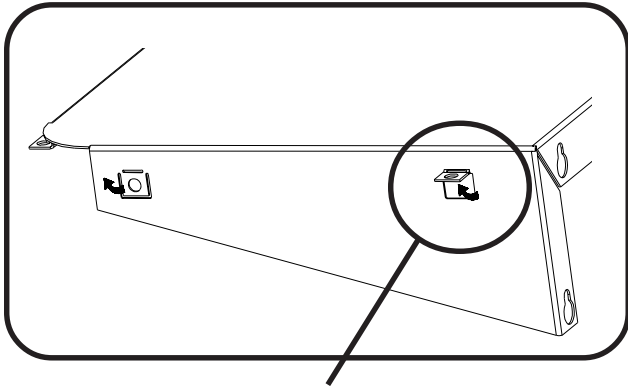

Bend tabs on front of shelf up with a flat head screw driver, insert screw through tab and into end cap.

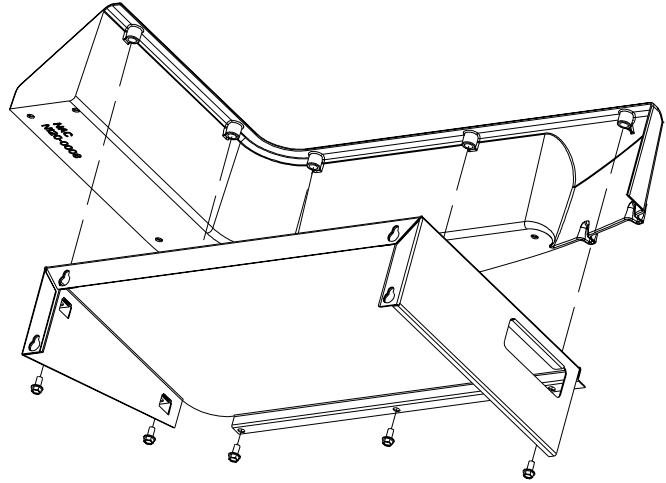

4 X

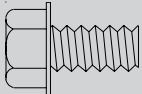

N570-0082 (1/4-20 x 5/8")

4 X



N735-0001 (1 1/16" insulated washer)

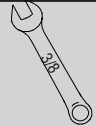

## 11 Side Shelf Installation

Insert (4) 1/4-20 x 5/8" screws through washers into threaded holes in side of base, do not tighten all the way. Slide assembled side shelf over screw heads and finish tightening.

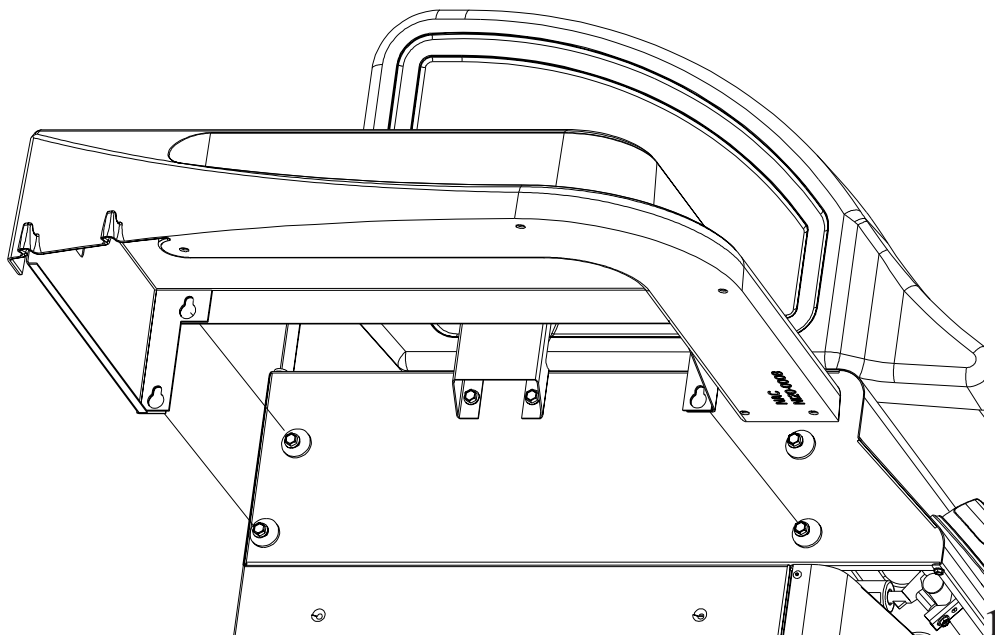
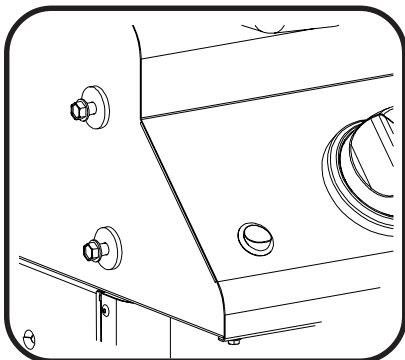

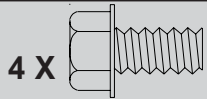

4 X

N570-0082 (1/4-20 X 5/8")

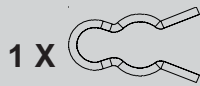

1 X

N160-0016



4 X

N735-0001 (1 1/16" insulated washer)



## 12 Side Burner Installation

Insert (4) 1/4-20 x 5/8" screws through washers into threaded holes in side of base. Do not tighten all the way. Slide assembled side burner over screw heads and finish tightening. Attach 1/2" flex connector hose from manifold to fitting on end of side burner hose. Fit orifice into burner tube and secure with hose retainer clip supplied. Attach wire from manifold to side burner electrode.

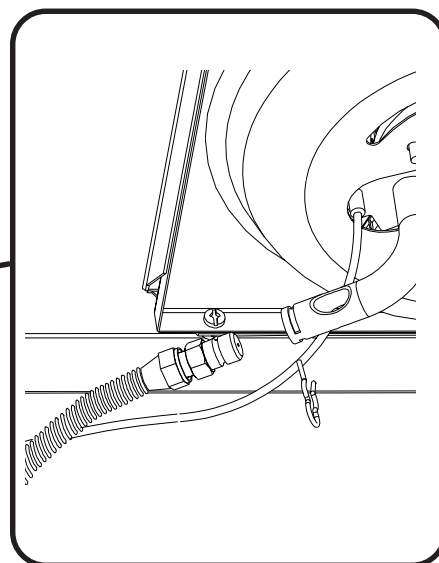
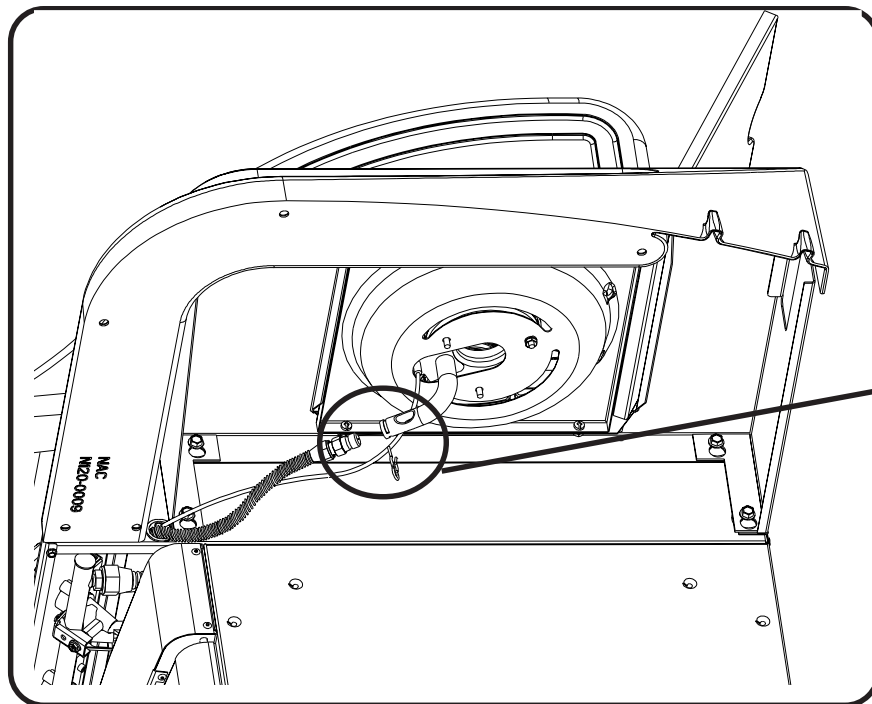
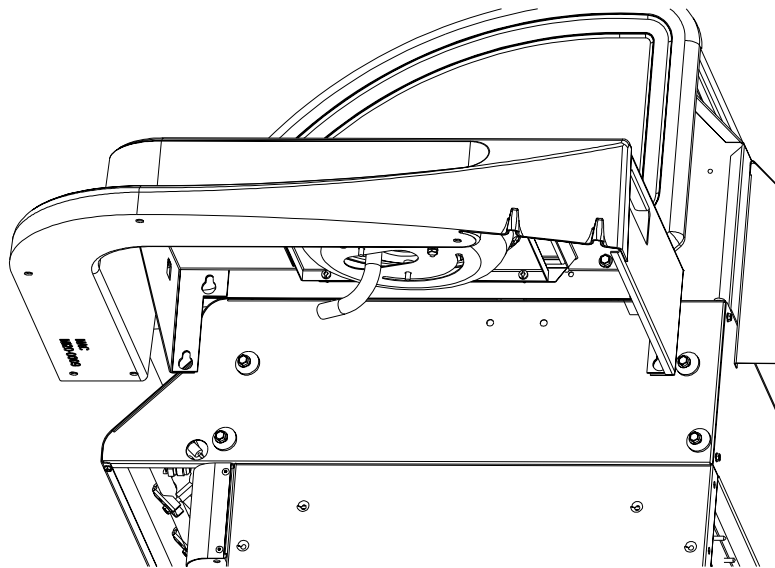
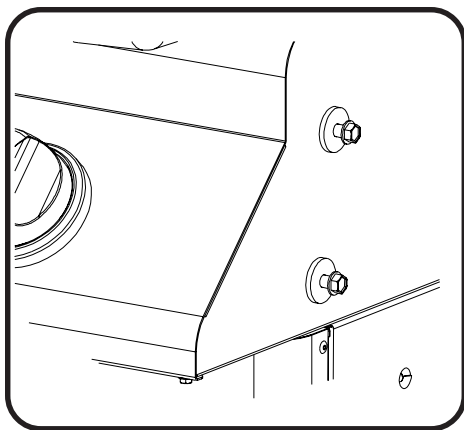

4 x N570-0073  
(1/4-20 X 3/8")

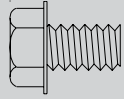

4 X N735-0003  
(1/4" LOCK WASHER)



2 x N105-0011  
DOOR BUSHING

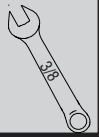
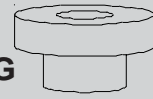

## 13 Cabinet Door Installation

Install door handle onto front of door using (2) 1/4-20 x 3/8" screws and (2) 1/4" lock washers per door.

Insert pivot rod through hole on inside top of door. Holding door in one hand, direct pivot rod into hole in underside of front cabinet support. Once secure, let rod slide down and through hole in bottom of door and into bushing in bottom shelf.

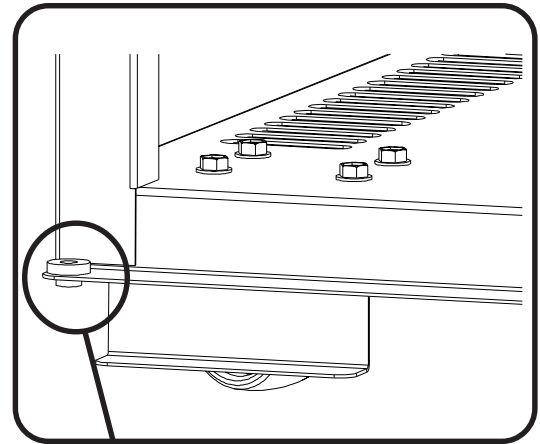
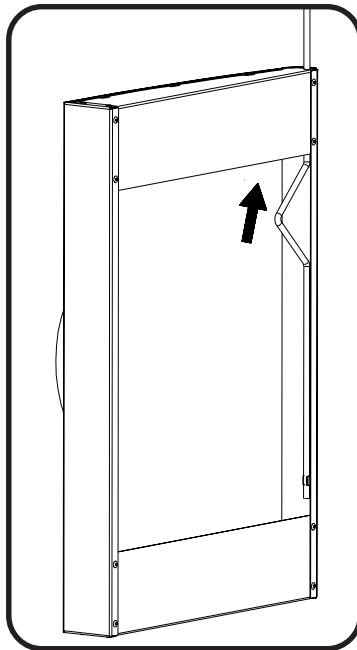
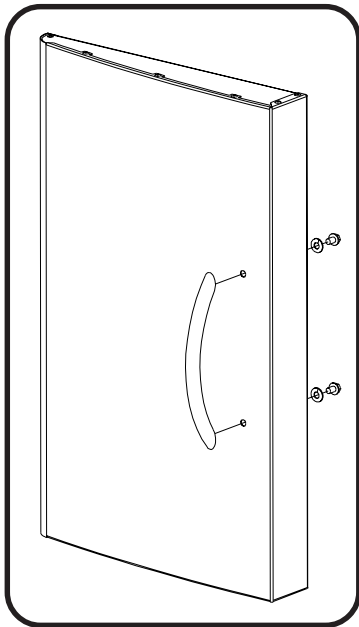

**BUSHING**

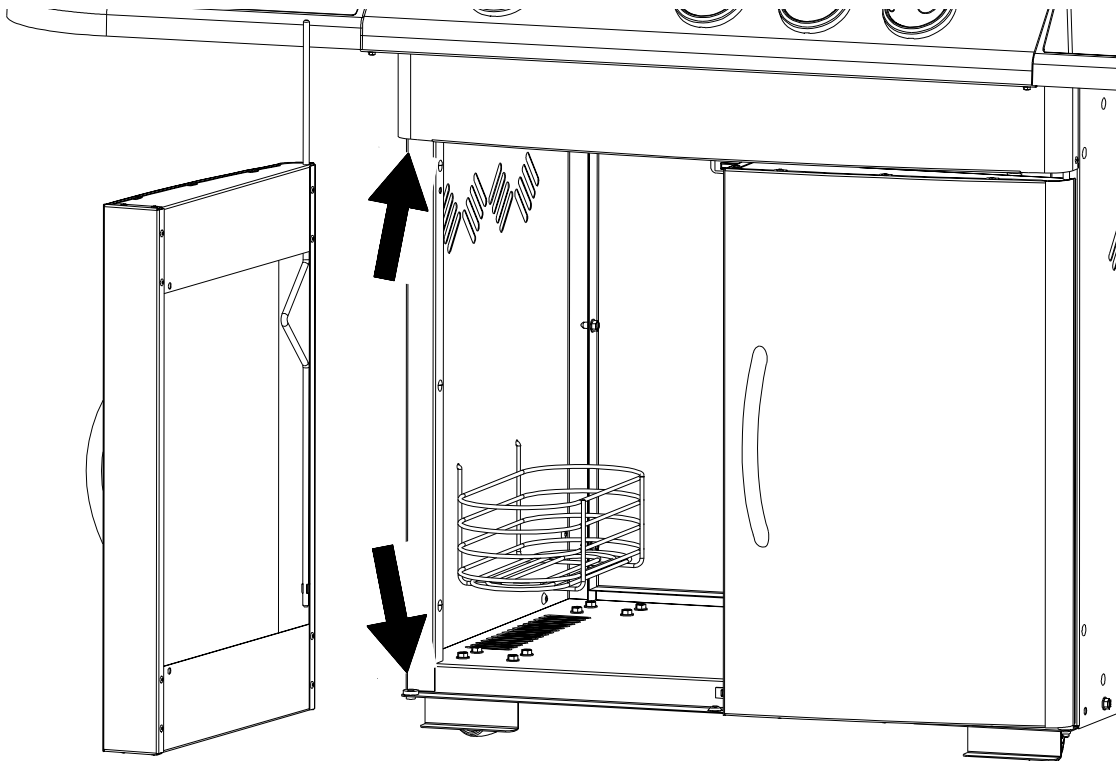

3 X N305-0057

## 14 Sear Plate Installation

Insert sear plates into base, position one over each tube burner with slots down to allow drippings to travel through.

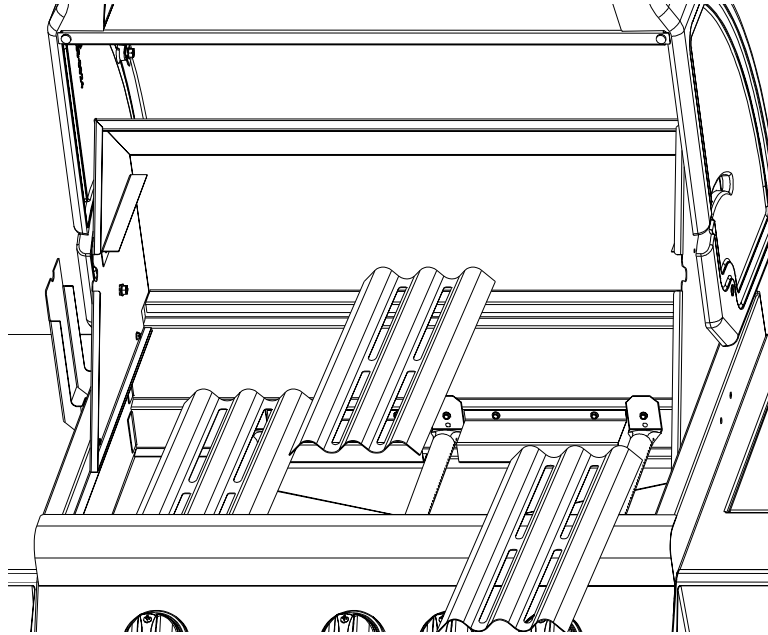

1 X N520-0023

2 X N305-0058

## 15 Grill and Warming Rack Installation

Position grills and warming rack into base as shown. Rest warming rack on brackets inside hood and grills on front and back lip of base.

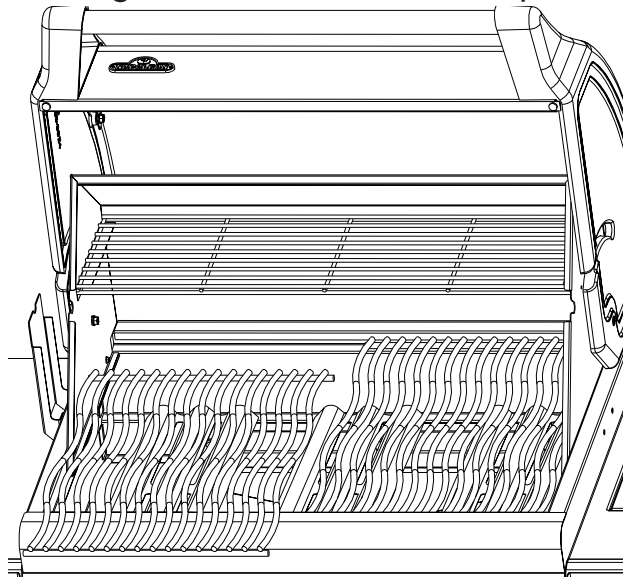

## 16 Grease Tray and Holder Installation

Clip the wire grease tray holder into the two holes located in the center of the back panel. Place the aluminum grease tray into the grease tray holder

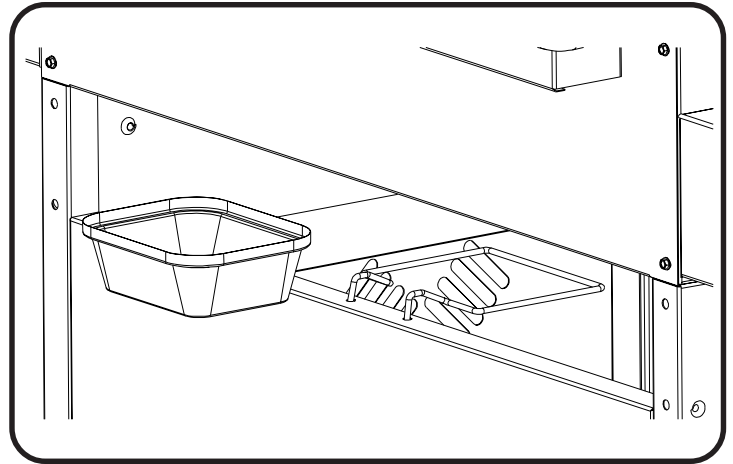
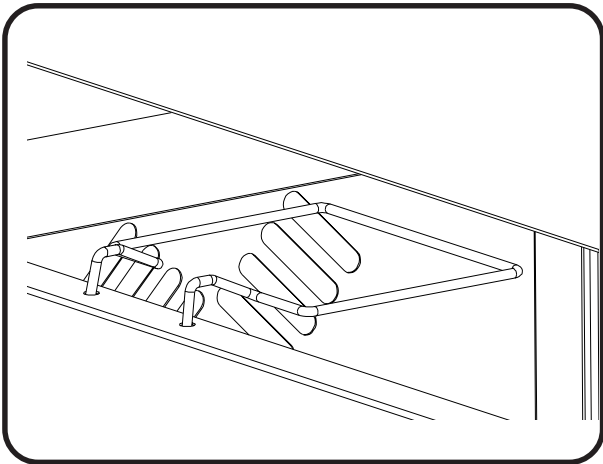

## 17 Drip Pan Installation

Slide drip pan into rear of base as shown. Ensure drip pan rides along rails on bottom of base.

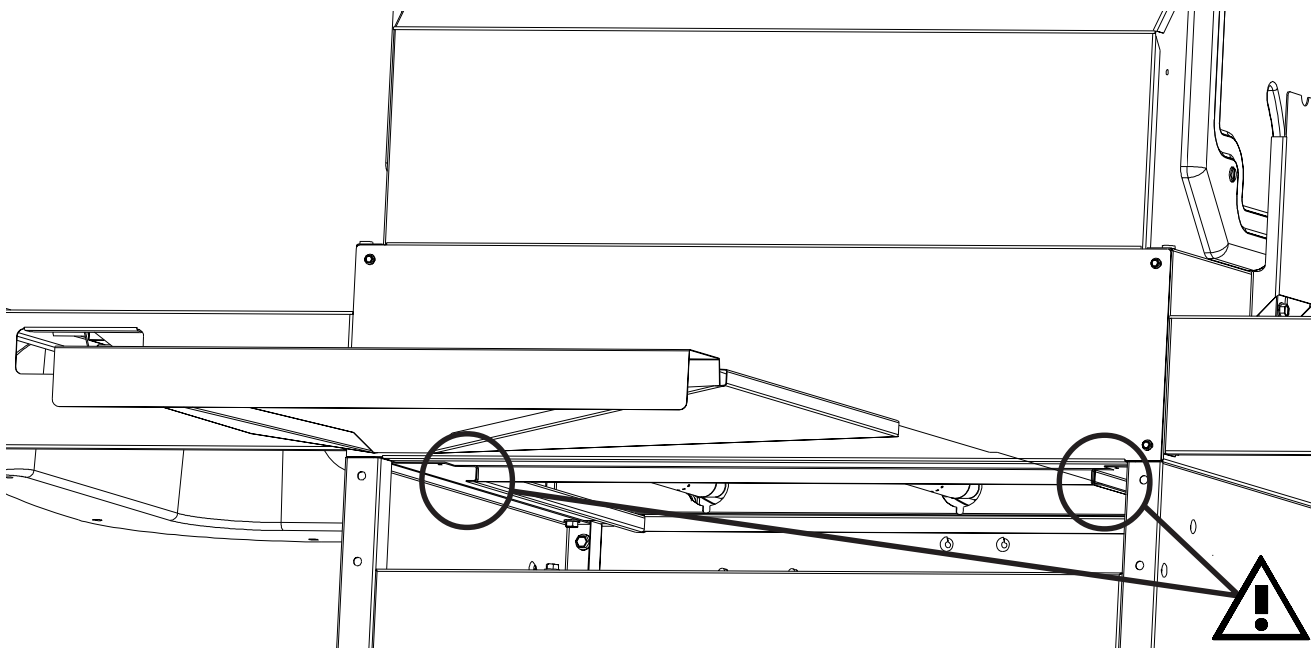



**PROPANE ONLY**

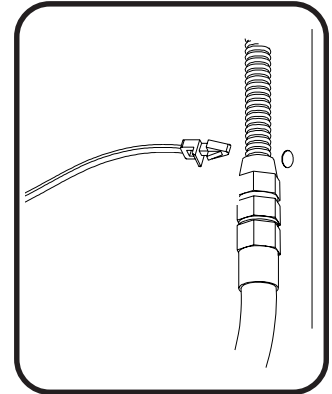
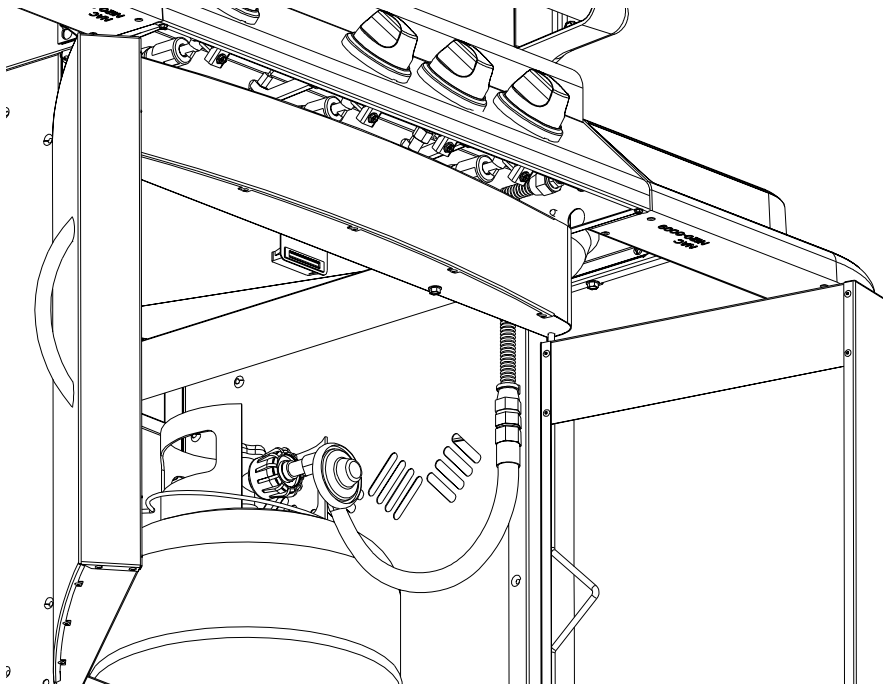

**CLIP HOSE TO SIDE PANEL USING HOSE RETAINER CLIP SUPPLIED**



**NATURAL GAS ONLY**



**1xN105-0002**

**2 X**

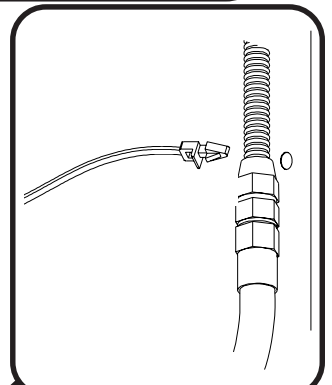
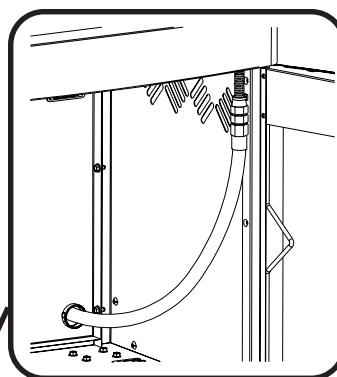
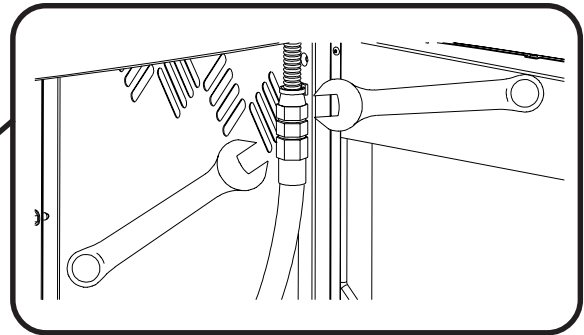
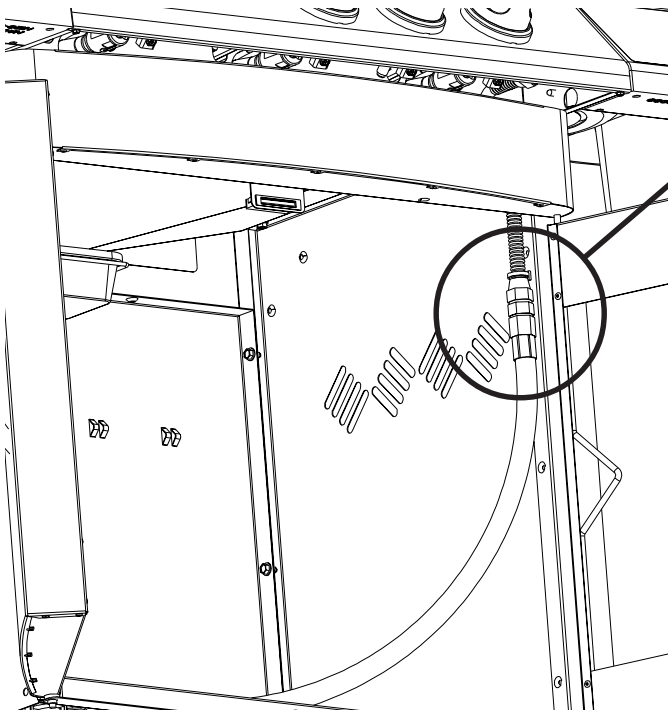
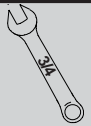

**INSTALL BUSHING INTO BACK PANEL**

**CLIP HOSE TO SIDE PANEL USING HOSE RETAINER CLIP SUPPLIED**



**THIS MUST BE PERFORMED BY A LICENSED GAS FITTER.  
DO NOT USE PIPE DOPE OR TEFLON TAPE ON THIS CONNECTION**

# LEAK TESTING INSTRUCTIONS



## DO NOT USE A FLAME TO LEAK TEST.

**LEAK TESTING:** This must be done before initial use, annually and whenever any gas components are replaced or serviced. No smoking while performing this test, and remove all sources of ignition. See *Leak Testing Diagram* for areas to check.

1. Turn all burner controls to off. Turn supply valve on.
2. Brush a half and half solution of liquid soap and water onto all joints and connections of the regulator, hose, manifolds and valves.
3. Bubbles will indicate a gas leak. Either tighten the loose joint or replace the part with one recommended by the dealer.
4. If the leak cannot be stopped, shut off the gas supply, disconnect it and have the barbecue inspected by your gas supplier or dealer. Do not use the appliance until the leak has been corrected.
5. Turn off gas supply.



**A LEAK TEST MUST BE PERFORMED AT THE FOLLOWING TIMES:**

- BEFORE INITIAL USE EVEN IF THE GRILL WAS DEALER ASSEMBLED.
- AT LEAST ONCE PER YEAR.
- WHENEVER ANY GAS COMPONENT HAS BEEN REPLACED.

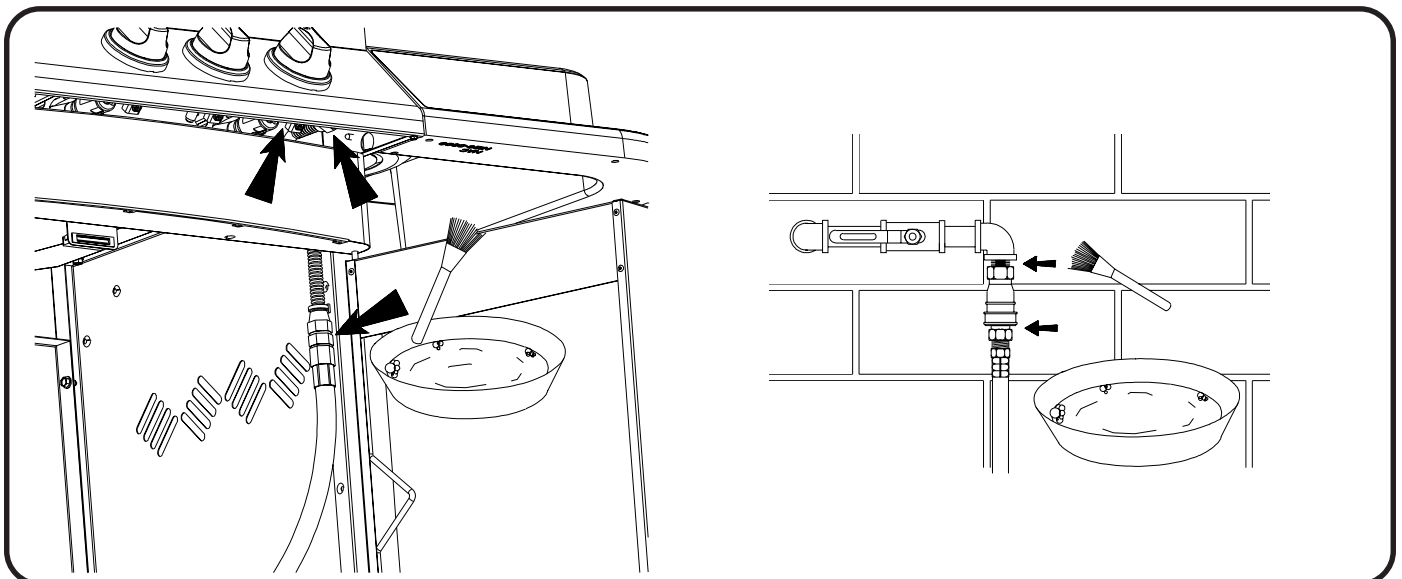
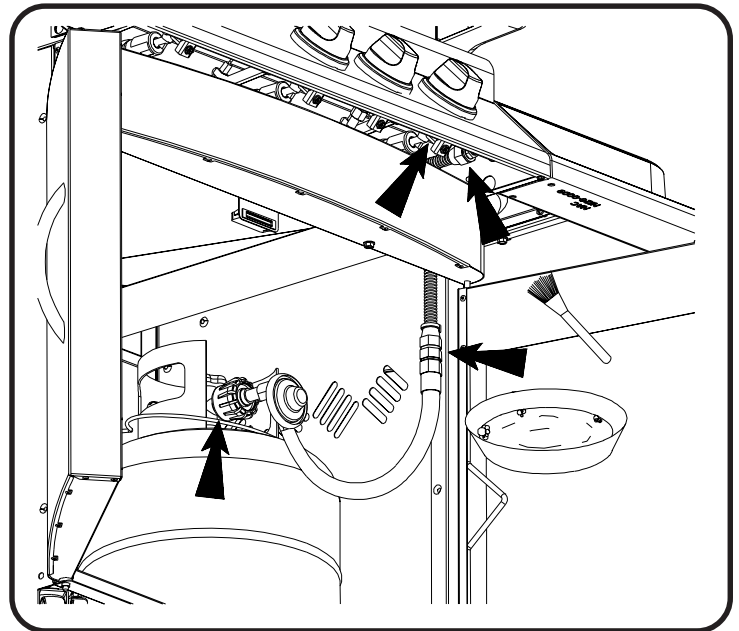

# PARTS LIST

Item	Part #	Description	485
1	N135-0024K	left side lid casting	x
2	N385-0129	NAPOLEON logo	x
3	W450-0005	logo spring clips	x
4	N510-0010	black silicone lid bumper	x
5	N685-0003	temperature gauge	x
6	N051-0004	temperature gauge bezel	x
7	N335-0042	stainless steel lid insert	x
8	N585-0040	heat shield lid	x
9	N010-0504	lid handle	x
10	N135-0025K	right side lid casting	x
11	N570-0015	lid pivot screw	x
12	N010-0502	hood assembly	x
13	N570-0008	#8 x 1/2" screw	x
14	N570-0073	1/4-20 x 3/8" screw	x
15	N735-0003	1/4" lockw asher	x
16	N520-0023	w arming rack	x
17	N305-0058	cooking grids - stainless rod	x
18	N305-0057	sear plate	x
19	N010-0529	stainless steel side shelf - right	x
20	N120-0009	LUXIDIO side shelf end cap, right	x
21	N570-0082	1/4-20 x 5/8" screw	x
22	N010-0528	stainless steel side shelf - left	x
23	N120-0008	LUXIDIO side shelf end cap, left	x
24	N500-0035K	side burner plate	x
25	N100-0037	side burner	x
26	N335-0043	side burner lid	x
27	N305-0059	side burner grate	x
28	N555-0019	side burner lid pivot rod	x
29	N100-0036	main burner	x
30	N080-0202	main burner cross light bracket	x
31	N475-0199	rotisserie mount	x
32	N010-0500	base	x
33	N010-0501	drip pan	x
34	N160-0014	grease tray holder	x
35	62007	replacement grease trays (5 pieces)	x
36	N200-0077P	back cover	x
37	N475-0181	control panel	x
38	N380-0011	control knob	x
39	N051-0003	control knob bezel	x
40	N530-0003	1-outlet regulator	p
	N345-0001	10ft n/g hose c/w quick disconnect	n
41	N010-0507	manifold assembly c/w valves	p

x - standard  
x - compris

p - propane units only  
n - natural gas units only  
ac - accessory

p - appareils propane seulement  
n - appareils gaz naturel seulement  
ac - accessoires



# PARTS LIST

Item	Part #	Description	485
	N010-0508	manifold assembly c/w valves	n
42	N720-0044	manifold flex connector	x
43	N255-0027	union fitting 3/8" - 3/8"	x
44	N725-0034	main burner valve c/w #56 orifice	p
	N725-0035	main burner valve c/w #52 orifice	n
45	N725-0032	side burner valve	p
	N725-0033	side burner valve	n
	N455-0049	side burner orifice #62	p
	N455-0050	side burner orifice #54	n
	N720-0055	side burner supply tube	x
47	N475-0183P	left/right side panel cabinet enclosure	x
48	N555-0018	door pivot rod	x
49	N010-0506	cart door assembly	x
50	N325-0048	door handle	x
	N570-0073	door handle screw s	x
52	N590-0147P	bottom shelf	x
53	N010-0505	front cabinet support	x
54	N475-0184P	rear cart panel	x
55	N585-0041P	heat shield	p
56	N105-0002	snap bushing	x
57	N105-0011	door bushings	x
58	N655-0094P	tank ring support	p
59	N430-0002	magnetic catch	x
	N020-0122	main assembly baggie	x
61	N750-0020	wiring harness led,	x
62	N190-0001	battery pack	x
	W043-0002	battery "AA"	x
64	N735-0001	insulated washer	x
	N105-0001	bushing 7/8"	x
66	N640-0001	hose retainer clip	x
67	N160-0015	propane tank clip	p
68	N130-0012	revolving caster	x
69	N450-0027	locking nut 1/4-20	x
70	N080-0212	stabilizer brackets	x
71	N590-0164	condiment basket	x
72	N130-0013	non revolving caster	x
	N370-0454	rotisserie kit	ac
	N555-0020	rotisserie spit	ac
	63485	vinyl cover	ac
	56017	stainless steel griddle	ac
	67730	charcoal tray	ac

x - standard  
x - compris

p - propane units only  
n - natural gas units only  
ac - accessory

p - appareils propane seulement  
n - appareils gaz naturel seulement  
ac - accessoires

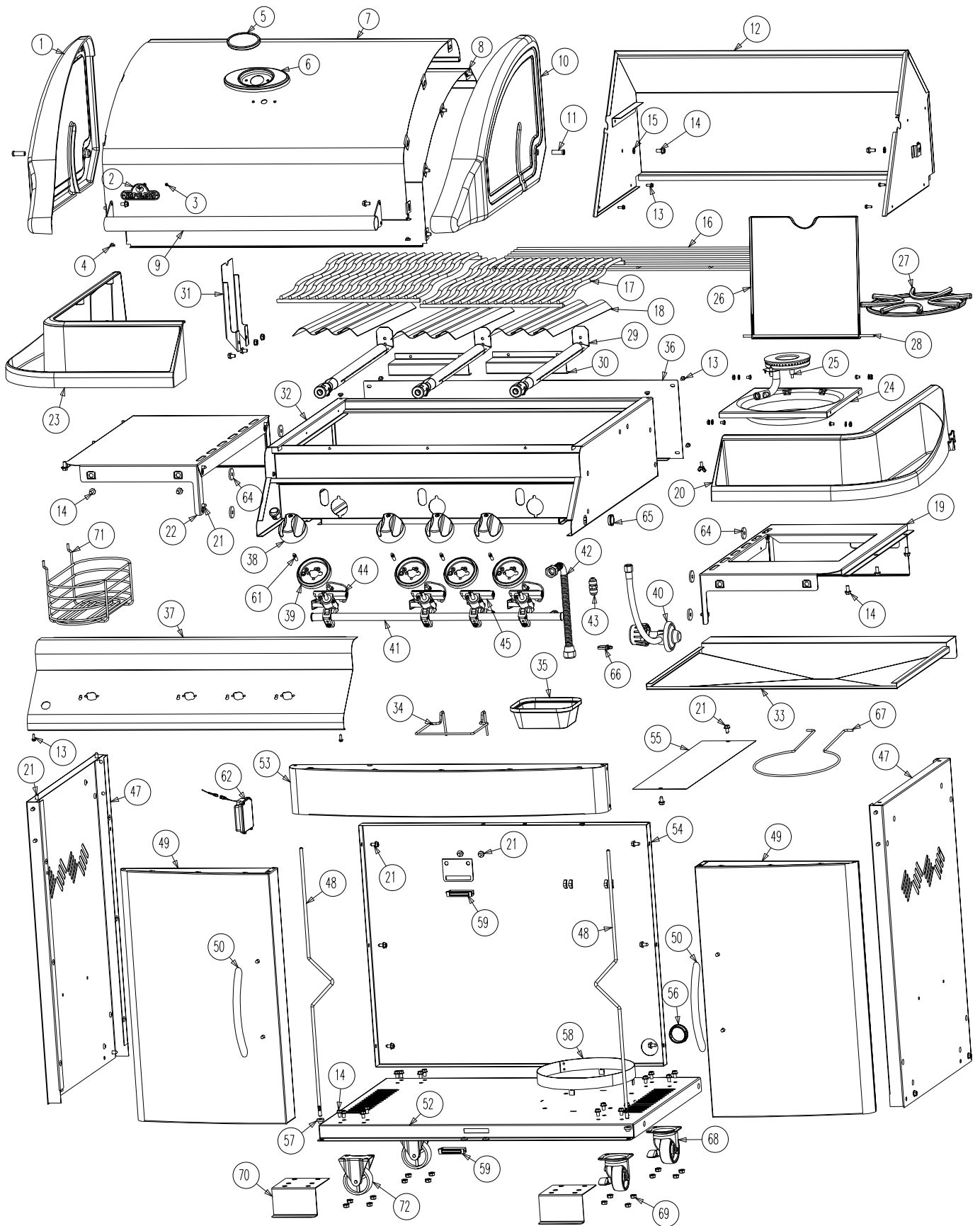

# NOTES

## NOTES